

All questions are for both separate science and combined science students

**Q1.**

A student investigated an orange dye (**A**) using paper chromatography.

**Figure 1** shows the results of Experiment 1 and Experiment 2 using orange dye **A**.

**Figure 1**

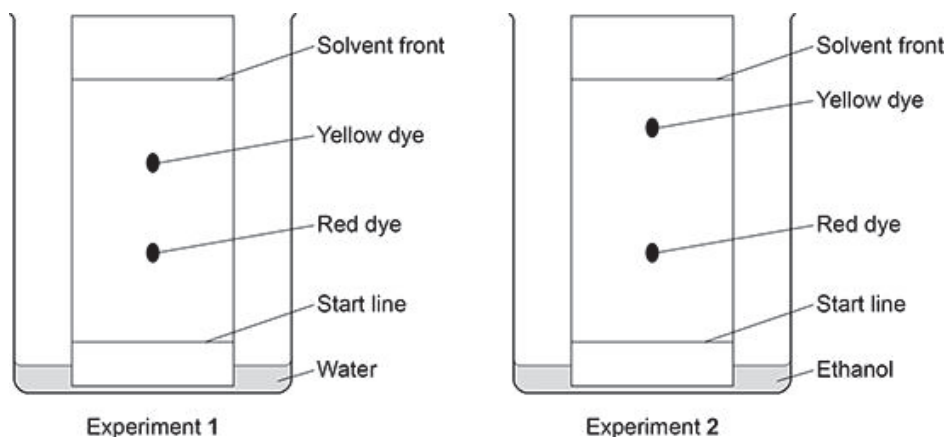

- (a) Explain why the yellow dye and red dye travel different distances in Experiment 1.

Refer to forces of attraction between the dyes and the chromatography paper in your answer.

---



---



---



---

(2)

- (b) The student used the same type of chromatography paper in Experiment 1 and in Experiment 2.

Explain why the yellow dye is in different positions in Experiment 1 and in Experiment 2.

Use **Figure 1**.

---



---



---



---



---

(3)

Figure 1 is repeated below.

Figure 1 shows the results of Experiment 1 and Experiment 2 using orange dye A.

Figure 1

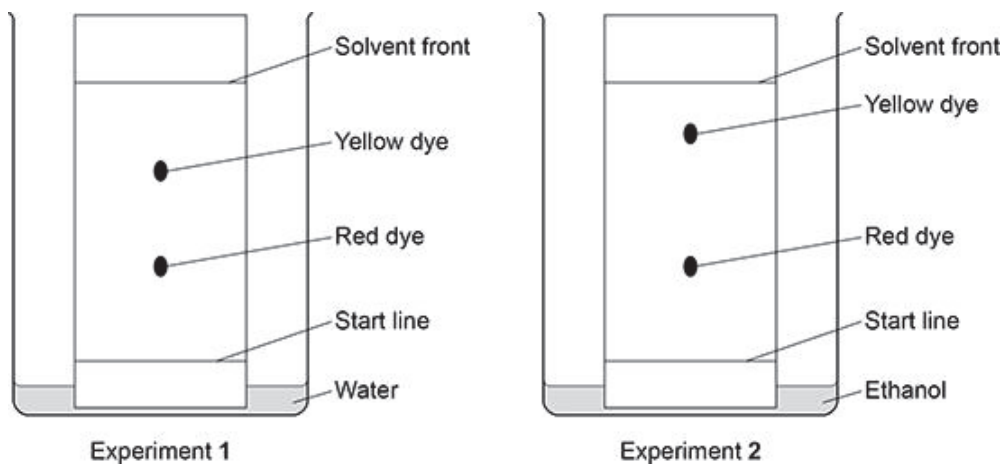

The student investigated a different orange dye (B).

Figure 2 shows the results of Experiment 3 using orange dye B.

Figure 2

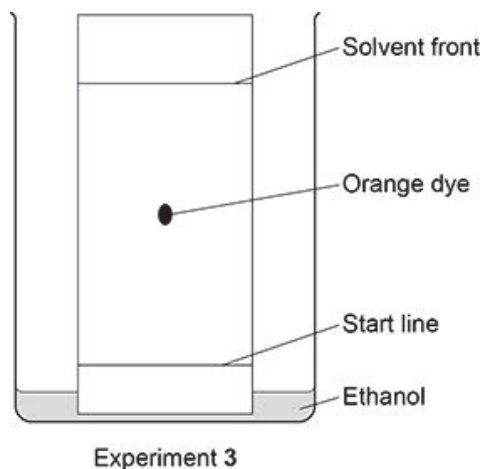

(c) Compare the purity of the orange dyes A and B.

Give reasons for your answer.

Use Figure 1 and Figure 2.

---



---



---



---

- (d) The student calculated that the  $R_f$  value of the orange dye in the experiment shown in **Figure 2** was 0.48

Calculate the distance moved by the solvent front when the orange dye had moved 5.4 cm.

---

---

---

---

---

Distance moved by solvent front = \_\_\_\_\_ cm

(3)

- (e) Why is the  $R_f$  value of a dye **not** affected by how far the solvent front is allowed to travel?

---

---

(1)

- (f) Another type of chromatography is called gas chromatography.

Gas chromatography is an instrumental method of chemical analysis.

Scientists tested the orange dyes using gas chromatography.

Suggest **two** advantages of using the instrumental method of gas chromatography rather than paper chromatography.

1 \_\_\_\_\_

---

2 \_\_\_\_\_

---

(2)

(Total 13 marks)

**Q2.**

This question is about chromatography.

A student investigated an orange food colouring using two different types of chromatography paper.

The food colouring:

- contained a mixture of red and yellow dyes
- was soluble in water.

This is the method used.

1. Draw a start line on a piece of type **A** chromatography paper.
2. Put a spot of orange food colouring on the line.
3. Put the paper into a beaker containing water as a solvent.
4. Wait for the water to travel up the paper.
5. Measure the distance above the start line moved by the red and yellow dyes and the water.
6. Repeat steps 1 to 5 using type **B** chromatography paper.

The figure below shows how the student set up the apparatus.

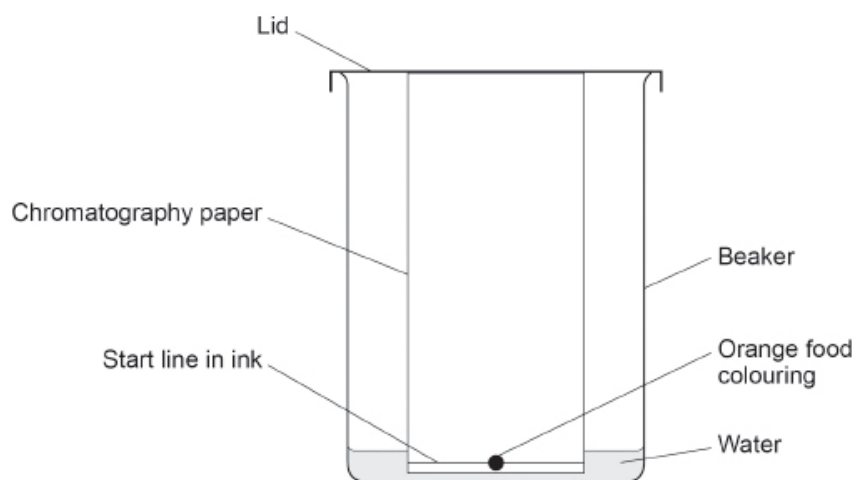

- (a) The student made **two** mistakes when setting up the apparatus.

Give **two** mistakes the student made.

1 \_\_\_\_\_

\_\_\_\_\_

2 \_\_\_\_\_

\_\_\_\_\_

Another student set up the apparatus correctly.

The table below shows the results.

|                               | Type A chromatography paper |            | Type B chromatography paper |            |
|-------------------------------|-----------------------------|------------|-----------------------------|------------|
|                               | Red dye                     | Yellow dye | Red dye                     | Yellow dye |
| Distance moved by dye in cm   | 4.8                         | 6.6        | 5.4                         | X          |
| Distance moved by water in cm | 12.0                        | 12.0       | 12.0                        | 12.0       |
| $R_f$ value                   | 0.40                        | 0.55       | 0.45                        | 0.60       |

(b) Determine value **X** in the table above.

---



---



---



---



---

**X** = \_\_\_\_\_ cm

(3)

Changing the type of chromatography paper resulted in different  $R_f$  values for the red dye.

(c) Explain why the  $R_f$  values for the red dye are different using the two types of chromatography paper.

Use the table above.

---



---



---



---



---



---

(3)

- (d) What other change to the investigation could result in a different  $R_f$  value for the red dye?

---

---

(1)

(Total 9 marks)