

All questions are for separate science students only

Q1.

This question is about salts.

- (a) Name the salt produced by the neutralisation of hydrochloric acid with potassium hydroxide.

(1)

- (b) Write an ionic equation for the neutralisation of hydrochloric acid with potassium hydroxide.

_____ + _____ → _____

(1)

- (c) Soluble salts can be produced by reacting dilute hydrochloric acid with an insoluble solid.

Copper, copper carbonate and copper oxide are insoluble solids.

Which of these insoluble solids can be used to make a copper salt by reacting the solid with dilute hydrochloric acid?

Tick (✓) **one** box.

Copper and copper carbonate only

Copper and copper oxide only

Copper carbonate and copper oxide only

Copper, copper carbonate and copper oxide

(1)

A student makes crystals of magnesium sulfate.

This is the method used.

1. Add sulfuric acid to a beaker.
2. Warm the sulfuric acid.
3. Add a spatula of magnesium oxide to the beaker.
4. Stir the mixture.
5. Repeat steps 3 and 4 until there is magnesium oxide remaining in the beaker.
6. Filter the mixture.
7. Evaporate the filtrate gently until crystals start to form.

8. Leave the solution to finish crystallising.

(d) Give **one** reason for:

- step 2
- step 5
- step 6.

Step 2 _____

Step 5 _____

Step 6 _____

(3)

(e) How should the filtrate be evaporated gently in **step 7**?

(1)

(f) Iron chloride is produced by heating iron in chlorine gas.

The equation for the reaction is:

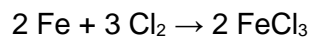

Calculate the volume of chlorine needed to react with 14 g of iron.

You should calculate:

- the number of moles of iron used
- the number of moles of chlorine that react with 14 g of iron
- the volume of chlorine needed.

Relative atomic mass (A_r): Fe = 56

The volume of 1 mole of gas = 24 dm³

Volume of chlorine = _____ dm³

(3)

(Total 10 marks)

Q2.

This question is about the reaction between hydrogen sulfide (H₂S) and oxygen.

The equation for the reaction is:

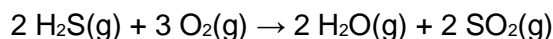

- (a) What does H₂O(g) represent?

(1)

- (b) Calculate the volume of oxygen required to react with 50 cm³ of hydrogen sulfide.

Volume = _____ cm³

(1)

- (c) **Figure 1** shows part of the reaction profile for the reaction.

The reaction is exothermic.

Complete **Figure 1**.

You should:

- complete the profile line
- label the activation energy
- label the overall energy change.

Figure 1

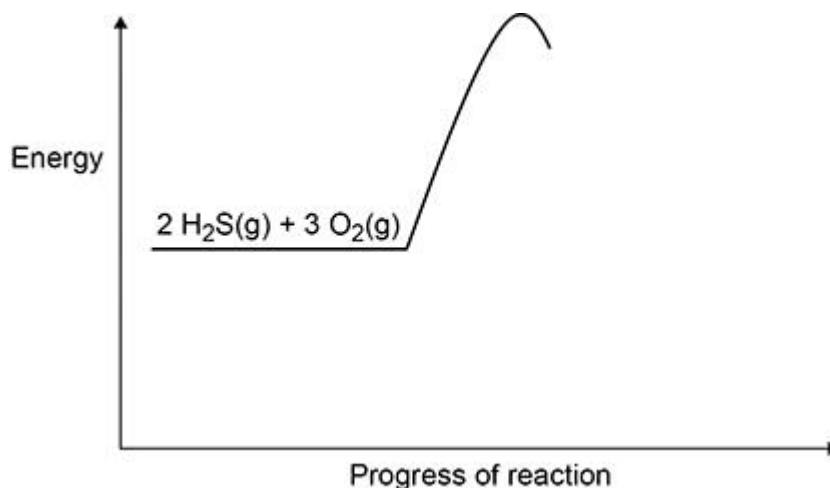

(3)

- (d) **Figure 2** shows the displayed formula equation for the reaction of hydrogen sulfide with oxygen.

Figure 2

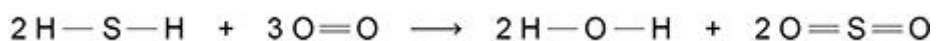

The table below shows some of the bond energies.

Bond	H—S	O=O	H—O	S=O
Energy in kJ/mol	364	498	464	X

In the reaction the energy released forming new bonds is 1034 kJ/mol greater than the energy needed to break existing bonds.

Calculate the bond energy **X** for the bond.

Use **Figure 2** and the table above.

X = _____ kJ/mol

(5)

(Total 10 marks)

Q3.

The reaction between hydrogen and oxygen releases energy.

- (a) A student drew a reaction profile for the reaction between hydrogen and oxygen.

Figure 1 shows the student's reaction profile.

Figure 1

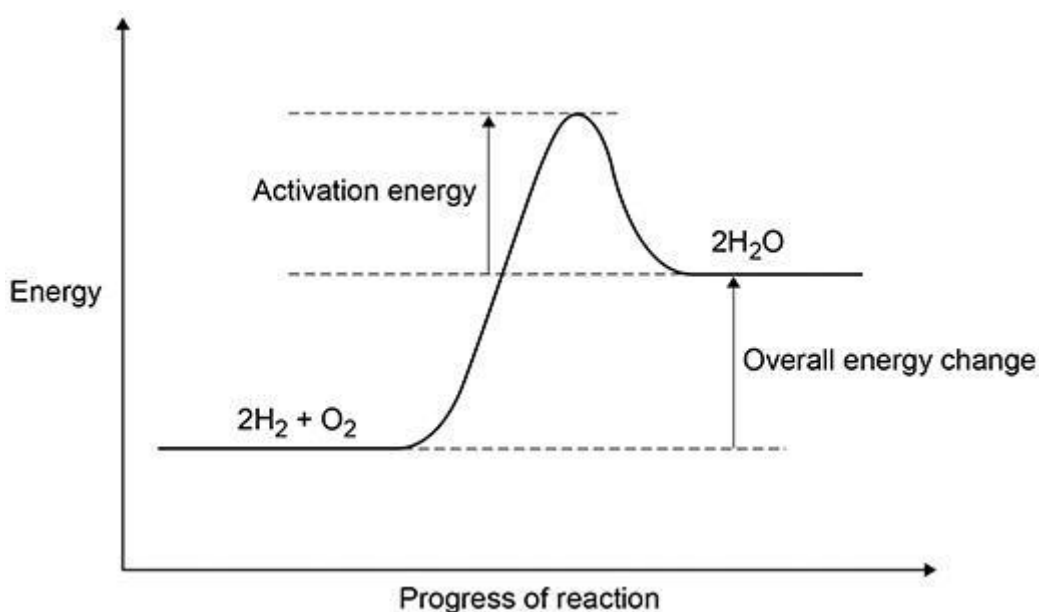

The student made **two** errors when drawing the reaction profile.

Describe the **two** errors.

- 1 _____

 2 _____

(2)

- (b) The reaction between hydrogen and oxygen in a hydrogen fuel cell is used to produce electricity.

Hydrogen fuel cells and rechargeable cells are used to power some cars.

Give **two** advantages of using hydrogen fuel cells instead of using rechargeable cells to power cars.

1 _____

2 _____

(2)

- (c) Reactions occur at the positive electrode and at the negative electrode in a hydrogen fuel cell.

Write a half equation for **one** of these reactions.

(1)

- (d) The three states of matter can be represented by a simple particle model.

Figure 2 shows a simple particle model for hydrogen gas.

Figure 2

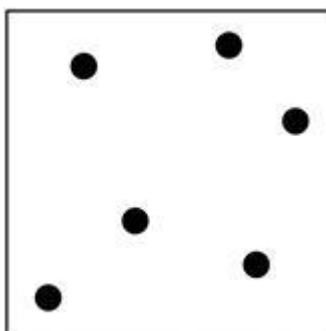

Give **two** limitations of this simple particle model for hydrogen gas.

1 _____

2 _____

(2)

- (e) The hydrogen gas needed to power a car for 400 km would occupy a large volume.

Suggest **one** way that this volume can be reduced.

(1)

- (f) The energy needed for a car powered by a hydrogen fuel cell to travel 100 km is 58 megajoules (MJ).

The energy released when 1 mole of hydrogen gas reacts with oxygen is 290 kJ

The volume of 1 mole of a gas at room temperature and pressure is 24 dm³

Calculate the volume of hydrogen gas at room temperature and pressure needed for the car to travel 100 km

Volume of hydrogen gas = _____ dm³

(4)

(Total 12 marks)

Q4.

This question is about electrolysis.

Aluminium is produced by electrolysis of a molten mixture of aluminium oxide and cryolite.

- (a) Explain why a mixture is used as the electrolyte instead of using only aluminium oxide.

(2)

- (b) What happens at the negative electrode during the production of aluminium?

Tick (✓) **one** box.

Aluminium atoms gain electrons.

Aluminium atoms lose electrons.

Aluminium ions gain electrons.

Aluminium ions lose electrons.

(1)

(c) Oxygen is produced at the positive electrode.

Complete the balanced half-equation for the process at the positive electrode.



(2)

(d) Explain why the positive electrode must be continually replaced.

(3)

(e) The overall equation for the electrolysis of aluminium oxide is:

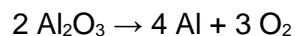

Calculate the mass of oxygen produced when 2000 kg of aluminium oxide is completely electrolysed.

Relative atomic masses (A_r): O = 16 Al = 27

Mass of oxygen = _____ kg

(4)

Sodium metal and chlorine gas are produced by the electrolysis of molten sodium chloride.

- (f) Explain why sodium chloride solution **cannot** be used as the electrolyte to produce sodium metal.

(2)

- (g) Calculate the volume of 150 kg of chlorine gas at room temperature and pressure.

The volume of one mole of any gas at room temperature and pressure is 24.0 dm³

Relative formula mass (M_r): Cl₂ = 71

Volume = _____ dm³

(2)

(Total 16 marks)

Q5.

This question is about combustion of fuels.

- (a) Some central heating boilers use wood as a fuel.

Suggest **two** reasons why wood is more sustainable than natural gas as a fuel for central heating boilers.

1 _____

2

(2)

Natural gas is mainly methane.

When methane burns it can produce both carbon monoxide and carbon dioxide.

- (b) Explain the process by which carbon monoxide can be produced when methane is burned.

(2)

- (c) Balance the equation for the combustion of methane to produce carbon monoxide.

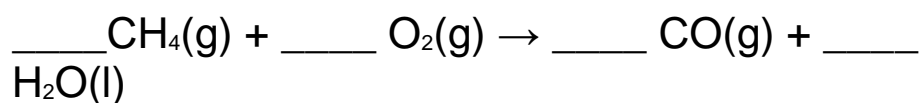

(1)

- (d) Propane burns to form carbon dioxide and water.

The equation for the reaction is:

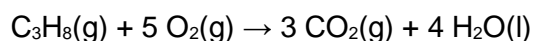

3.60 dm³ carbon dioxide is produced when a sample of propane is burned in 7.25 dm³ oxygen.

Calculate the volume of unreacted oxygen.

Give your answer in cm³

Volume of unreacted oxygen = _____ cm³

(4)

(Total 9 marks)

Q6.

A student investigated the electrolysis of different substances.

Figure 1 shows the apparatus.

Figure 1

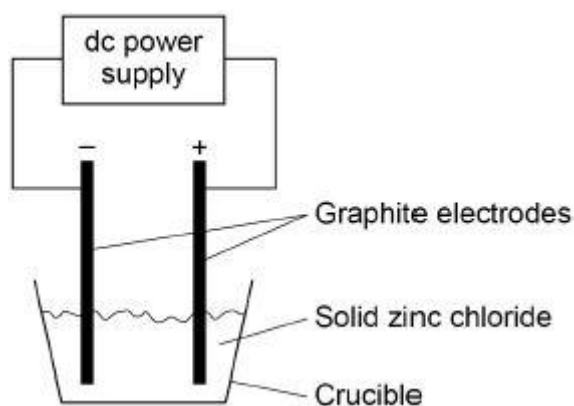

- (a) Explain why electrolysis would not take place in **Figure 1**.

(2)

- (b) Explain why graphite conducts electricity.

Answer in terms of the structure and bonding in graphite.

(3)

The student investigated how the volume of gases produced changes with time in the electrolysis of sodium chloride solution.

Figure 2 shows the apparatus.

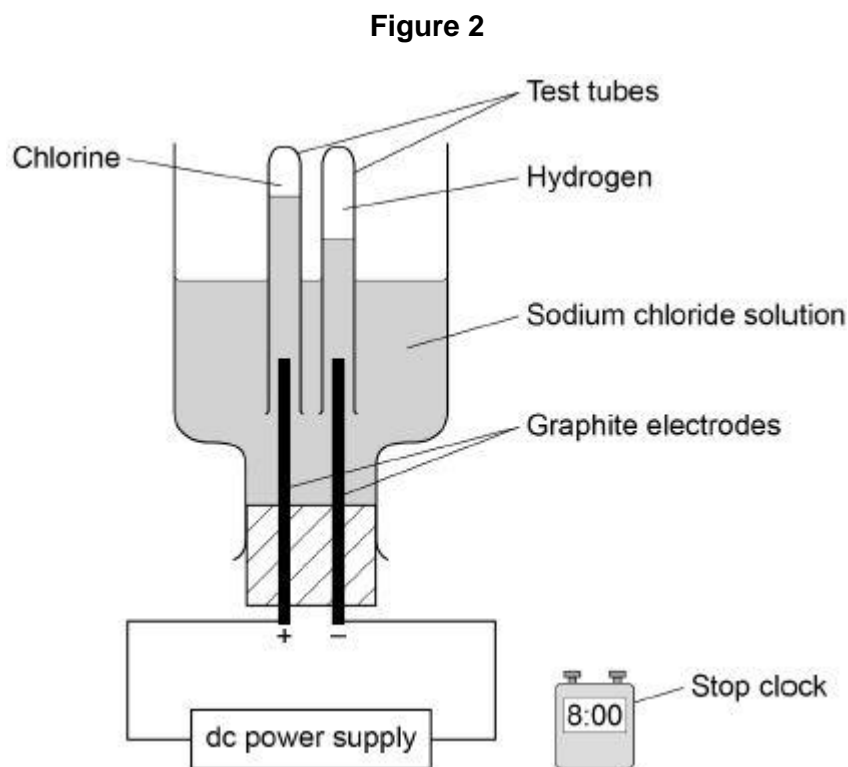

(c) The student made an error in selecting the apparatus for this investigation.

How should the apparatus be changed?

Give **one** reason for your answer.

(2)

Another student used the correct apparatus.

This student measured the volumes of gases collected every minute for 20 minutes.

Figure 3 shows the student's results.

Figure 3

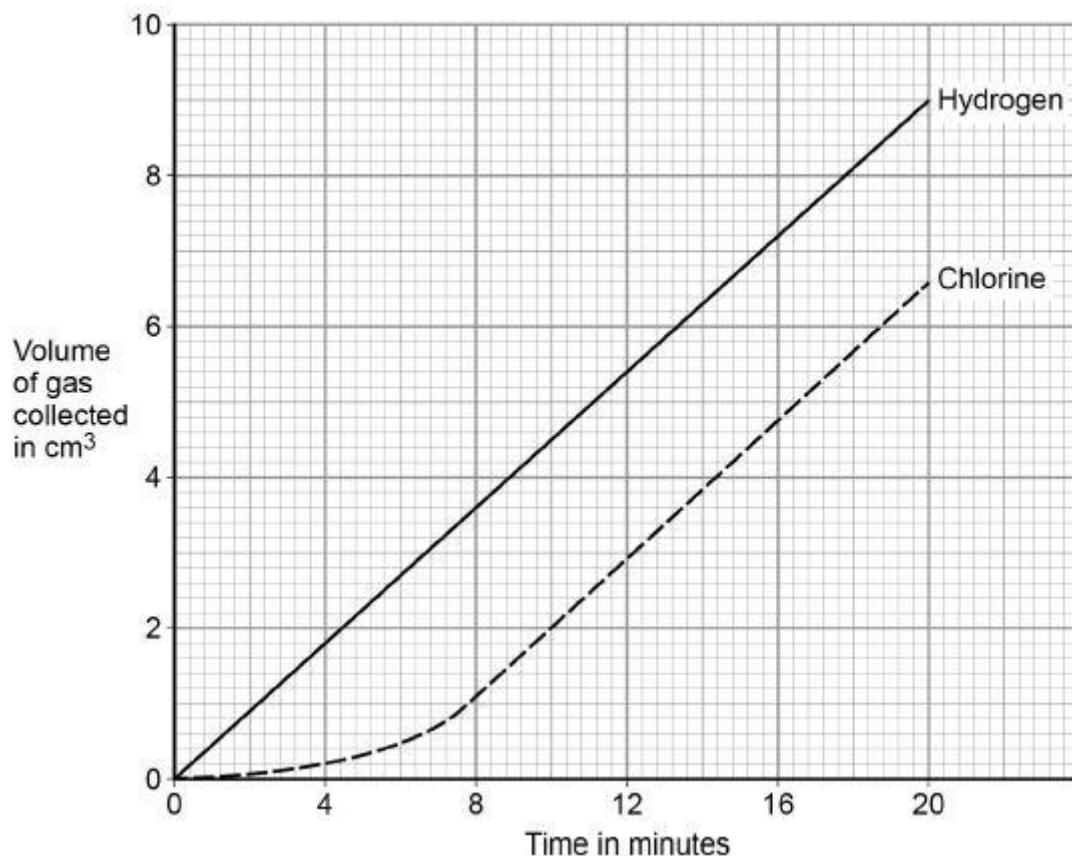

(d) Describe the trends shown in the results.

Use values from **Figure 3**.

(3)

(e) The number of moles of each gas produced at the electrodes is the same.

No gas escapes from the apparatus.

Suggest **one** reason for the difference in volume of each gas collected.

(1)

(f) Calculate the amount in moles of chlorine collected after 20 minutes.

Use **Figure 3**.

The volume of one mole of any gas at room temperature and pressure is 24.0 dm^3

Give your answer in standard form.

Moles of chlorine = _____ mol

(3)

(Total 14 marks)

Q7.

Nitrogen and hydrogen react to produce ammonia in the Haber process.

Figure 1 shows the Haber process.

Figure 1

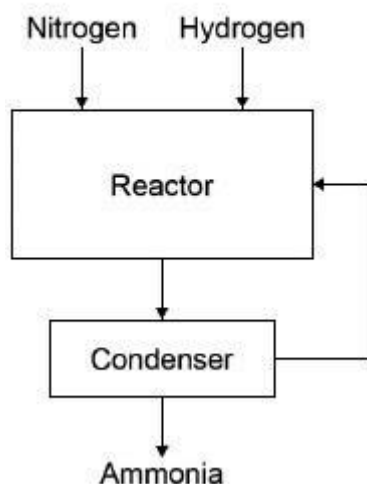

A gaseous mixture of ammonia, hydrogen and nitrogen leaves the reactor.

Table 1 shows the boiling points of the gases.

Table 1

Gas	Boiling point in °C
Ammonia	-33
Nitrogen	-196

Hydrogen	-253
----------	------

- (a) Suggest how ammonia is separated from the other gases.

(2)

- (b) What happens to the unreacted hydrogen and nitrogen?

(1)

The equation for the reaction is:

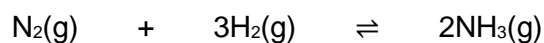

The forward reaction is exothermic.

- (c) Calculate the volume of ammonia produced from the complete reaction of 825 dm³ of hydrogen.

Volume of ammonia = _____ dm³

(2)

- (d) The Haber process uses a temperature of 450 °C and a pressure of 200 atmospheres.

Why are these conditions used?

Tick **two** boxes.

A higher pressure is maintained using less energy

A higher temperature would increase the equilibrium yield

A lower pressure would decrease the equilibrium yield

A lower temperature would make the reaction too slow

There are more product molecules than reactant molecules

(2)

Most of the ammonia produced is used to make fertilisers.

Table 2 shows information about compounds used as fertilisers.

Table 2

Compound	Formula	Cost in £ / tonne
A	NH_4NO_3	220
B	$(\text{NH}_4)_2\text{HPO}_4$	350
C	KCl	235

(e) Which element in compound A improves agricultural productivity?

(1)

(f) Which **two** compounds can be mixed to make a fertiliser containing three elements that improve agricultural productivity?

Give a reason why you have chosen these compounds.

Compounds _____ and _____

Reason

(2)

(g) **Figure 2** shows a flow chart for the production of compounds B and C.

Figure 2

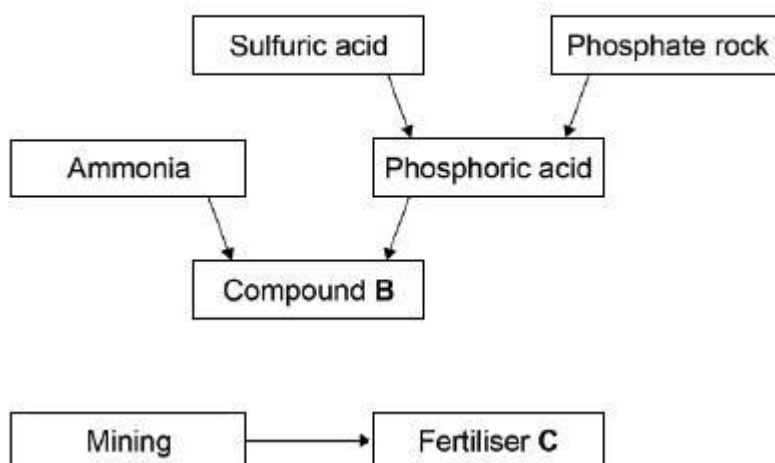

Suggest **two** possible reasons for the difference in cost between compounds **B** and **C**.

1. _____

2. _____

(2)
(Total 12 marks)