

Please write clearly in block capitals.

Centre number

Candidate number

Surname _____

Forename(s) _____

Candidate signature _____

GCSE PHYSICS

H

Higher Tier Paper 2

Friday 14 June 2019

Morning

Time allowed: 1 hour 45 minutes

Materials

For this paper you must have:

- a ruler
- a scientific calculator
- a protractor
- the Physics Equations Sheet (enclosed).

Instructions

- Use black ink or black ball-point pen.
- Fill in the box at the top of this page.
- Answer **all** questions in the spaces provided.
- Do not write outside the box around each page or on blank pages.
- Do all rough work in this book. Cross through any work you do not want to be marked.
- In all calculations, show clearly how you work out your answer.

Information

- The maximum mark for this paper is 100.
- The marks for questions are shown in brackets.
- You are expected to use a calculator where appropriate.
- You are reminded of the need for good English and clear presentation in your answers.

| For Examiner's Use | |
|--------------------|------|
| Question | Mark |
| 1 | |
| 2 | |
| 3 | |
| 4 | |
| 5 | |
| 6 | |
| 7 | |
| 8 | |
| 9 | |
| 10 | |
| TOTAL | |



Answer **all** questions in the spaces provided.

Do not write
outside the
box

0 1 . 1 Figure 1 shows parallel rays of light being refracted by a convex lens.

Figure 1

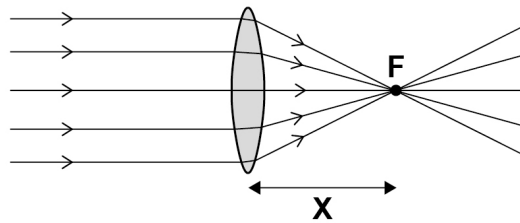

What is distance 'X' called?

[1 mark]

0 1 . 2 Lenses can be used to form the image of an object.

Complete the ray diagram in **Figure 2** to show how a **convex** lens forms the image of the object.

Use an arrow to represent the image.

[2 marks]

Figure 2

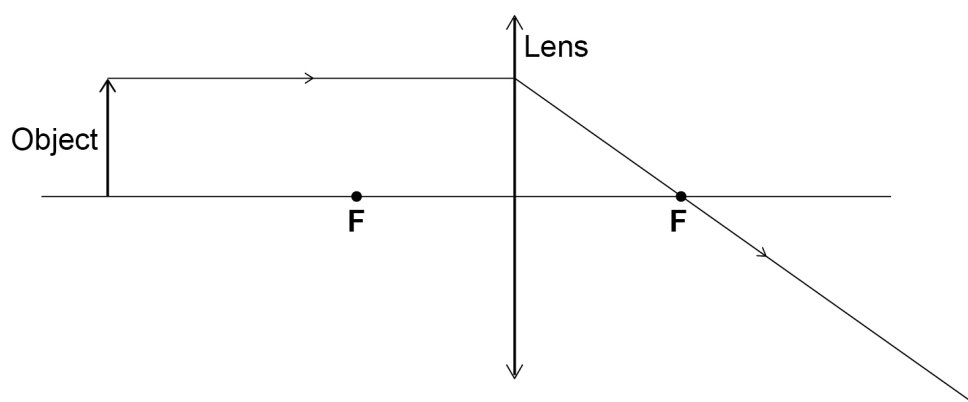
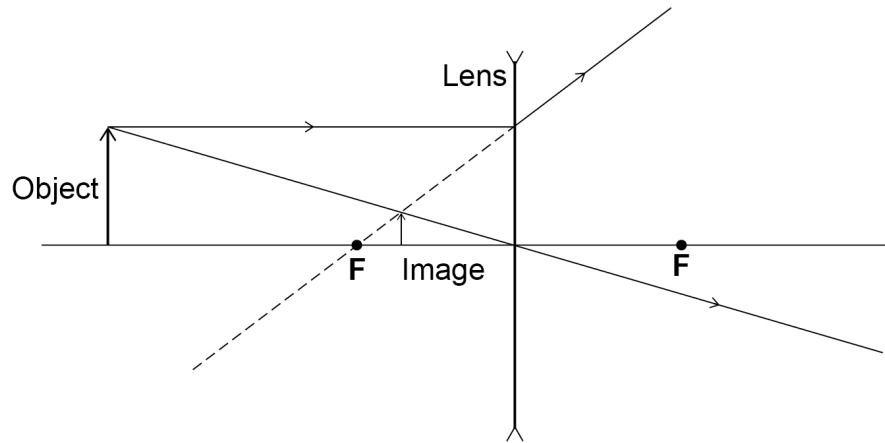

Figure 3 shows how a **concave** lens forms the image of an object.

Do not write
outside the
box

Figure 3



0 1 . 3

Give **one** similarity and **one** difference between the image formed by the convex lens and the image formed by the concave lens.

[2 marks]

Similarity _____

Difference _____

0 1 . 4

A person uses a lens to read the letters on the back of a coin.

The image height of the letters on the coin is 9.0 mm

The magnification produced by the lens is 6.0

Calculate the height of the letters on the coin.

Use the Physics Equations sheet.

[3 marks]

Height = _____ mm

8

Turn over ►



0 2

Figure 4 shows the apparatus used to investigate the waves in a stretched string.

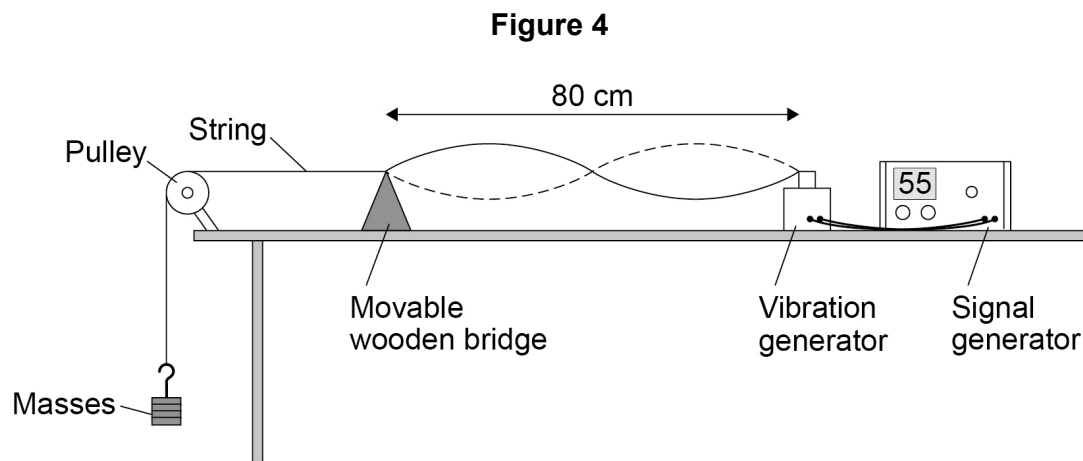

The frequency of the signal generator is adjusted so that the wave shown in **Figure 4** is seen.

At this frequency the string vibrates between the two positions shown in **Figure 4**.

0 2 . 1

The wavelength of the wave shown in **Figure 4** was measured as 80 cm

What piece of apparatus would have been suitable for measuring this wavelength?

[1 mark]

0 2 . 2

Write down the equation which links frequency, wavelength and wave speed.

[1 mark]

0 2 . 3

The string in **Figure 4** vibrates at 55 Hz

Calculate the wave speed of the wave shown in **Figure 4**.

Use data given in **Figure 4**.

[3 marks]

Wave speed = _____ m/s



0 3 . 2 Write down the equation which links distance, force and work done.

[1 mark]

0 3 . 3 The work done by the braking force to stop a vehicle was 900 000 J

The braking force was 60 000 N

Calculate the braking distance of the vehicle.

[3 marks]

Braking distance = _____ m

0 3 . 4 The greater the braking force, the greater the deceleration of a vehicle.

Explain the possible dangers caused by a vehicle having a large deceleration when it is braking.

[2 marks]

Turn over for the next question

Turn over ►



0 4 . 1 Figure 5 shows a solenoid.

Draw the magnetic field of the solenoid on **Figure 5**.

[2 marks]

Figure 5

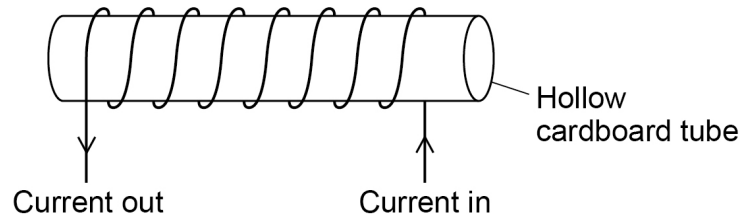

0 4 . 2 Figure 6 shows two iron rods placed inside a solenoid.

Figure 6

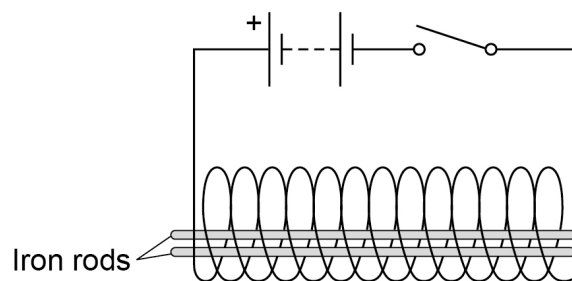

Explain why the iron rods move apart when the switch is closed.

[2 marks]



A student investigated the strength of an electromagnet.

The student investigated how the strength depended on:

- the current in the wire
- the number of turns of wire around the iron core.

Figure 7 shows the equipment used.

Figure 7

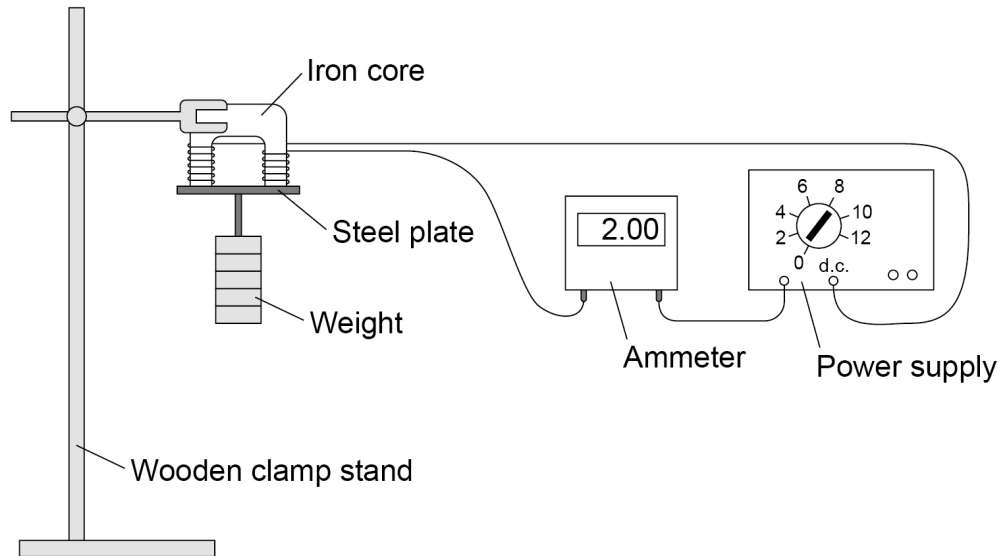

The student measured the strength of the electromagnet as the maximum weight the electromagnet could hold.

0 4 . 3

Table 1 shows the results.

Table 1

| Current in amps | Number of turns of wire | Maximum weight in newtons |
|-----------------|-------------------------|---------------------------|
| 1.0 | 30 | 6.5 |
| 1.5 | 20 | 6.4 |
| 2.0 | 10 | 3.7 |

Explain why the method used by the student is **not** valid for this investigation.

[2 marks]

Turn over ►



A second student repeated the investigation using the same equipment.

Figure 8 shows the second student's results.

Figure 8

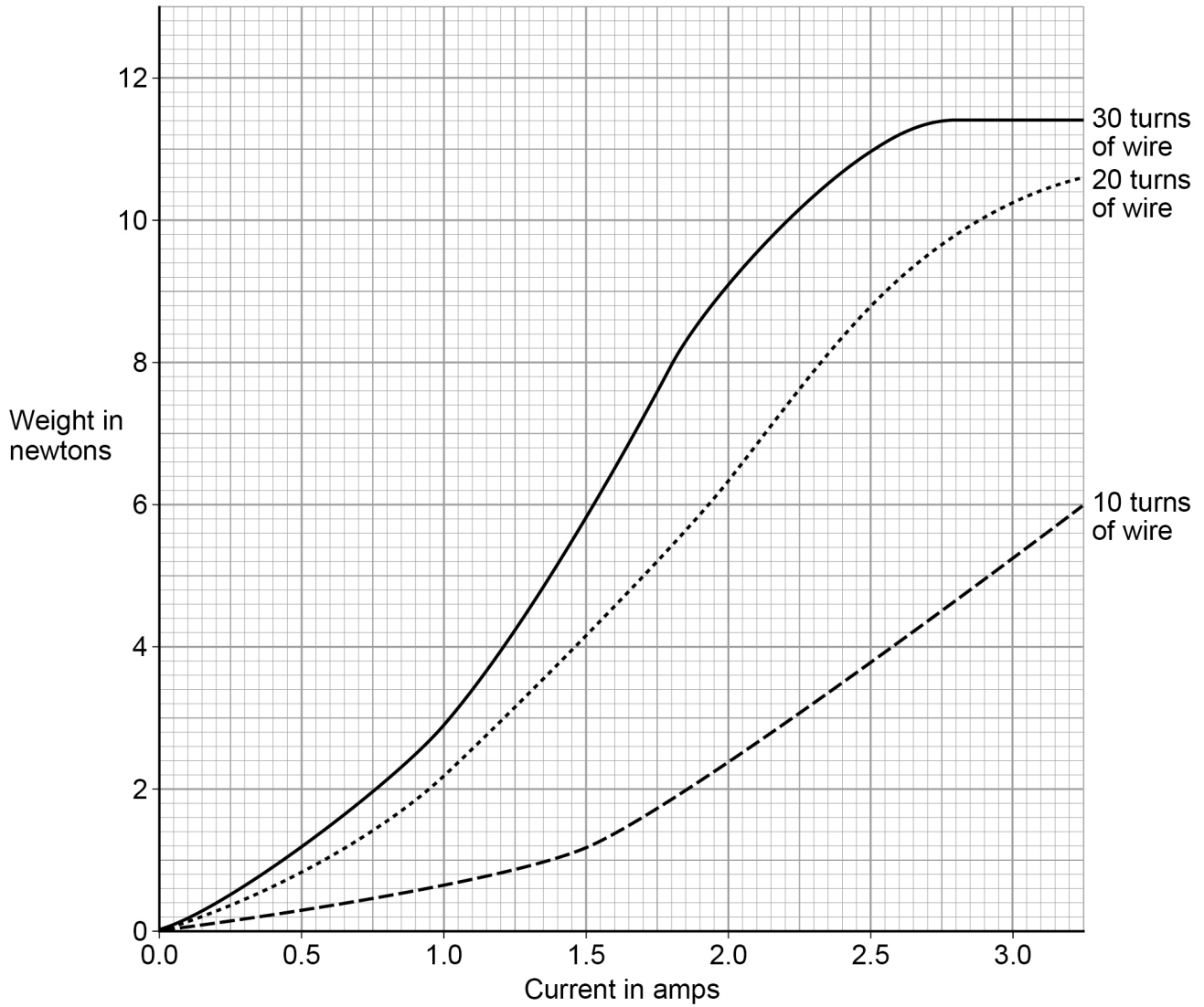

0 4 . 4

How does increasing the current in the wire affect the strength of the electromagnet, when the electromagnet has 30 turns of wire?

[1 mark]



0 4 . 5

How does increasing the number of turns of wire from 10 to 20 affect the strength of the electromagnet, compared to increasing the number of turns of wire from 20 to 30?

[1 mark]

8

Turn over for the next question

Turn over ►

0 5 . 1 The light from distant galaxies shows red-shift.

Complete the sentence.

[1 mark]

The term red-shift describes the observed increase

in the _____ of the light from a distant galaxy.

0 5 . 2 The Big Bang theory is one model used to explain the origin of the universe.

How does the Big Bang theory describe the universe when it began?

[1 mark]

Figure 9 shows data scientists have calculated from measurements of red-shift.

Figure 9

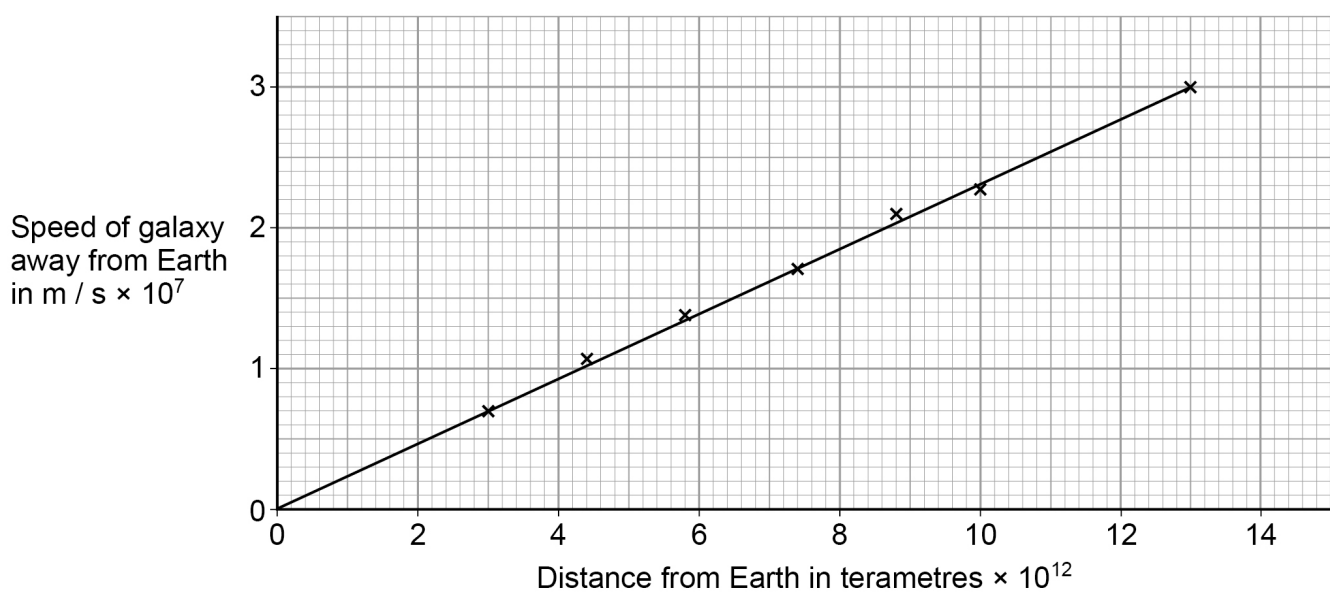

0 5 . 3 Describe the relationship between the speed of a galaxy and the distance the galaxy is from the Earth.

[1 mark]

0 5 . 4 Which of the following is the same as 6×10^{12} terametres?

[1 mark]

Tick (✓) **one** box.

6×10^{15} m

6×10^{18} m

6×10^{21} m

6×10^{24} m

0 5 . 5 Explain how the data in **Figure 9** supports the suggestion that the universe began from a very small region.

[2 marks]

Question 5 continues on the next page

Turn over ►



0 5 . 6 The Big Bang theory suggested that gravity would slow the rate at which galaxies move away from the Earth.

New observations suggest that distant galaxies are moving away from the Earth at an increasingly fast rate.

What do the new observations suggest is happening to the universe?

[1 mark]

0 5 . 7 New observations and data that do not fit existing theories should undergo peer review.

Give **one** reason why peer review is an important process.

[1 mark]

0 5 . 8 The Andromeda galaxy is moving towards the Earth.

Describe how the wavelength and frequency of the light from Andromeda seem to have changed when viewed from the Earth.

[2 marks]



0 6 . 1 An adult of mass 80 kg has more inertia than a child of mass 40 kg

What is inertia?

[1 mark]

0 6 . 2 A teacher demonstrated the idea of a safety surface.

She dropped a raw egg into a box filled with pieces of soft foam.

The egg did not break.

Figure 10 shows the demonstration.

Figure 10

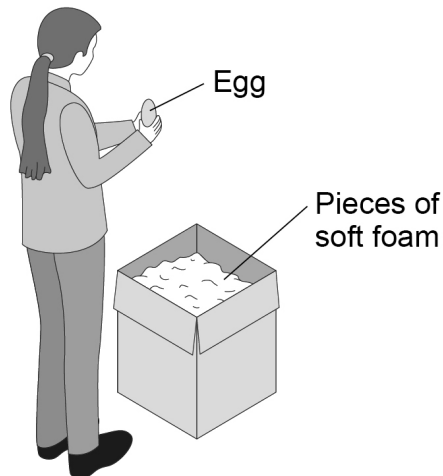

Explain why the egg is less likely to break when dropped onto soft foam rather than onto a concrete floor.

[3 marks]

Turn over ►



0 6 . 3

Figure 11 shows a child on a playground swing. The playground has a rubber safety surface.

Figure 11

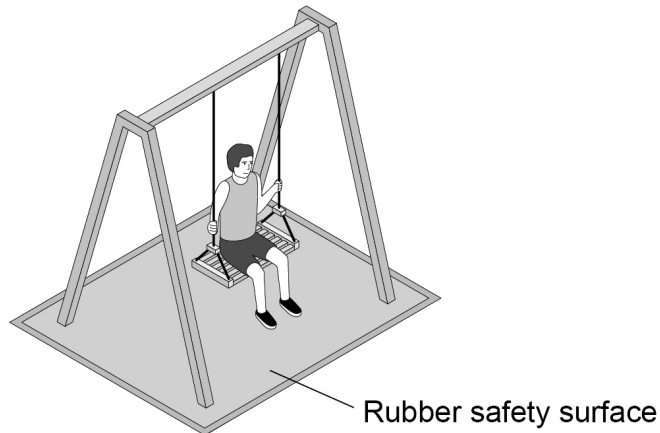

A child of mass 32 kg jumped from the swing.

When the child reached the ground she took 180 milliseconds to slow down and stop.

During this time an average force of 800 N was exerted on her by the ground.

Calculate the velocity of the child when she first touched the ground.

Use the Physics Equations Sheet.

[4 marks]

Velocity = _____ m/s

8



0 7 . 1 Figure 12 shows the electromagnetic spectrum.

Figure 12

| | | | | | | |
|-------|-----------|----------|---------------|-------------|-------|-------|
| Radio | Microwave | Infrared | Visible light | Ultraviolet | X-ray | Gamma |
|-------|-----------|----------|---------------|-------------|-------|-------|



Which statement is correct for the direction of the arrow in **Figure 12**?

[1 mark]

Tick (✓) **one** box.

The wavelength decreases and the wave speed in air increases.

The frequency increases and the wavelength increases.

The frequency increases and the wave speed in air stays the same.

The wavelength increases and the wave speed in air increases.

0 7 . 2 Explain how the properties of X-rays make them suitable for the medical imaging of bones.

[2 marks]

Question 7 continues on the next page

Turn over ►



A student investigated the infrared radiation emitted from the sides of a hollow metal cube.

The sides of the cube are different colours or textures.

Figure 13 shows the equipment used.

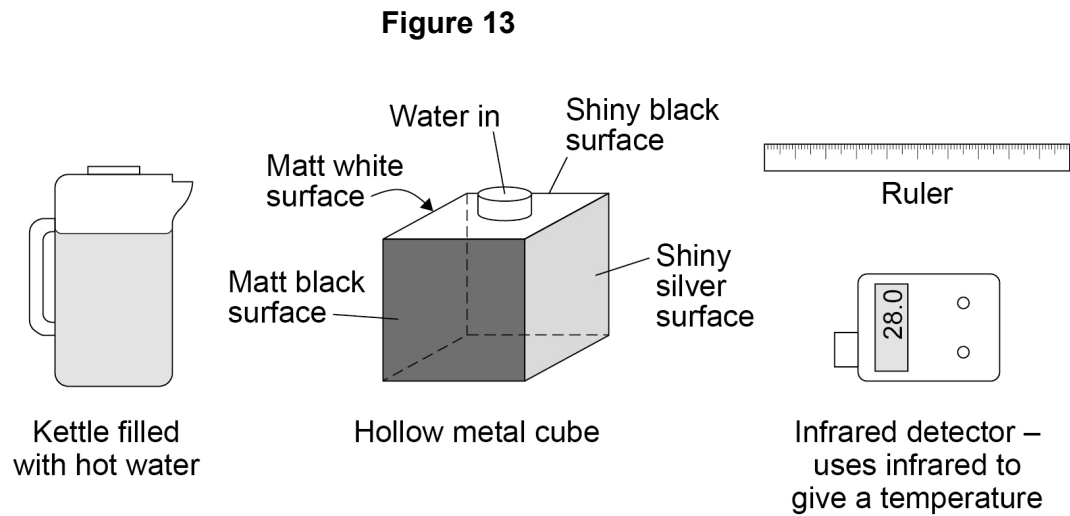

Boiling water was poured into the cube. The amount of infrared radiation emitted from each vertical surface was then measured.

07.3 Boiling water is a hazard in this investigation.

Suggest how the risk of harm could be reduced in this investigation.

[1 mark]

07.4 What is the control variable in this investigation?

[1 mark]



Table 2 shows the results.

Table 2

| Type of surface | Temperature in °C |
|-----------------|-------------------|
| Matt black | 68.0 |
| Matt white | 65.5 |
| Shiny black | 66.3 |
| Shiny silver | 28.0 |

- 0 7 . 5** The four temperature values in **Table 2** cannot be used to show that the infrared detector gives precise readings.

Give the reason why.

[1 mark]

- 0 7 . 6** The student looked at the data in **Table 2** and concluded:

‘A black surface always emits more infrared radiation than a white surface.’

Explain how using an infrared detector with a resolution of 1 °C would have affected the student’s conclusion.

[2 marks]

Turn over ►



Albedo is a measure of the amount of solar radiation reflected by an object compared to the total solar radiation incident on the object.

A perfect reflector has an Albedo value of 1.0
A perfect absorber has an Albedo value of 0.0

0 7 . 7

What is the Albedo value of a perfect black body?

[1 mark]

0 7 . 8

Figure 14 shows two points, **A** and **B**, just above the Earth's surface.

Figure 14

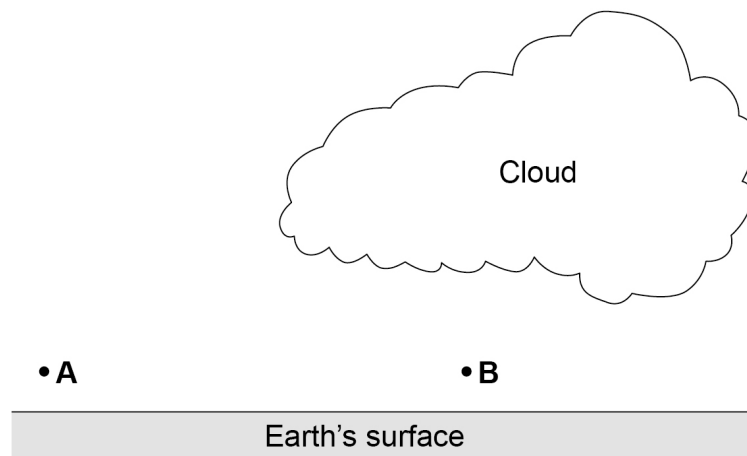

The average Albedo value of the Earth's surface is 0.3
The Albedo value of thick cloud varies between 0.6 and 0.9

At night the air at point **A** cools faster than the air at point **B**.

Explain why.

[3 marks]



Turn over for the next question

*Do not write
outside the
box*

**DO NOT WRITE ON THIS PAGE
ANSWER IN THE SPACES PROVIDED**

Turn over ►



0 8

An aeroplane is 4000 m above the Earth's surface.

A skydiver jumps from the aeroplane and falls vertically.

Figure 15 shows the distance the skydiver falls during the first 12 seconds after jumping.

Figure 15

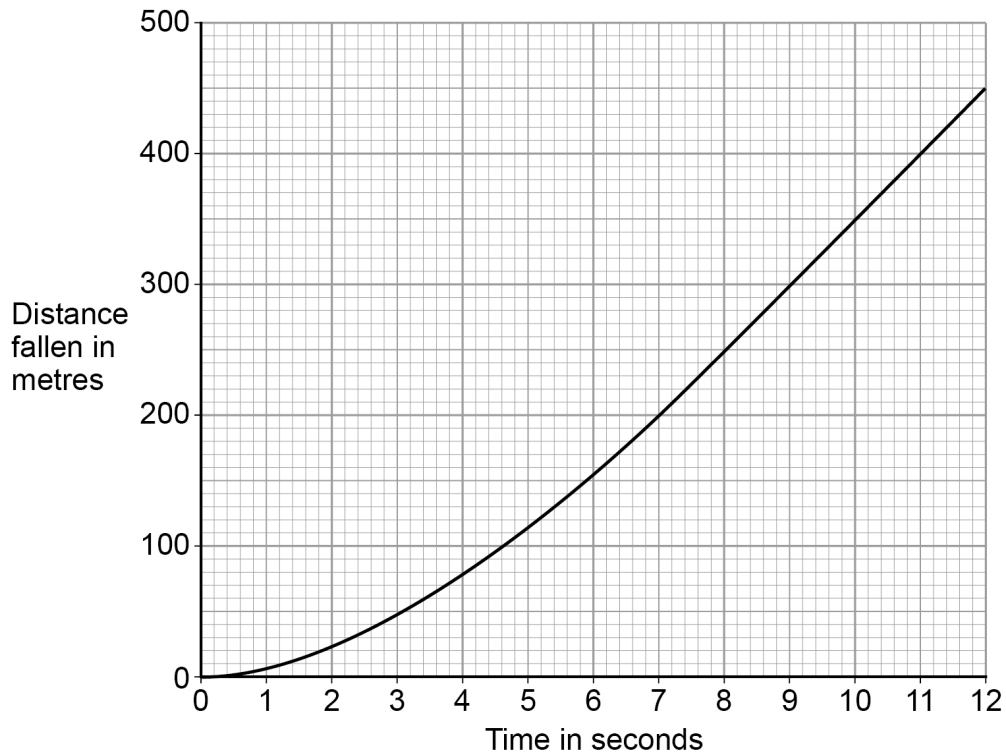

0 8 . 1

Figure 16 shows part of the free body diagram for the skydiver three seconds after jumping.

Complete the free body diagram for the skydiver.

[2 marks]

Figure 16

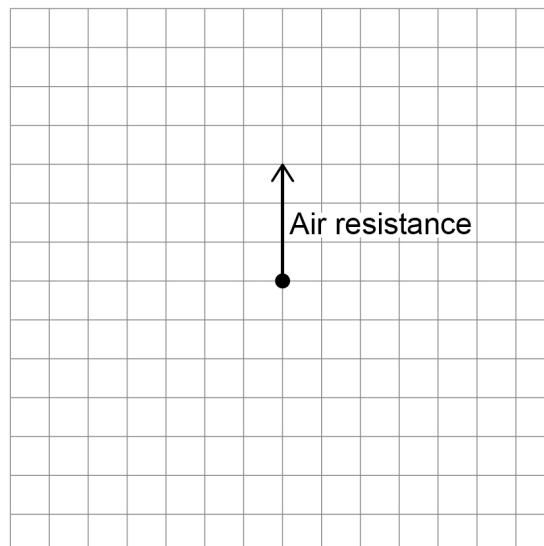

0 8 . 4

In 2012 a skydiver jumped from a helium balloon 39 000 metres above the Earth's surface. The skydiver reached a maximum speed of 377 m/s

Jumping from 39 000 metres allowed the skydiver to reach a much higher speed than a skydiver jumping from 4000 metres.

Explain why.

[3 marks]

12



Turn over for the next question

*Do not write
outside the
box*

**DO NOT WRITE ON THIS PAGE
ANSWER IN THE SPACES PROVIDED**

Turn over ►



0 9 . 1 Table 3 gives the frequencies in the hearing ranges of five different animals.

Table 3

| Animal | Frequencies of hearing range |
|---------|------------------------------|
| Cat | 55 Hz to 77 kHz |
| Chicken | 125 Hz to 2 kHz |
| Dog | 20 Hz to 30 kHz |
| Gerbil | 56 Hz to 60 kHz |
| Horse | 55 Hz to 33 kHz |

Which **one** of the animals from **Table 3** would not be able to hear ultrasound?

[1 mark]

Figure 17 shows ultrasound being used to detect a hidden crack in a solid aluminium object. The transmitted and reflected pulses of ultrasound are shown on the screen.

Figure 17

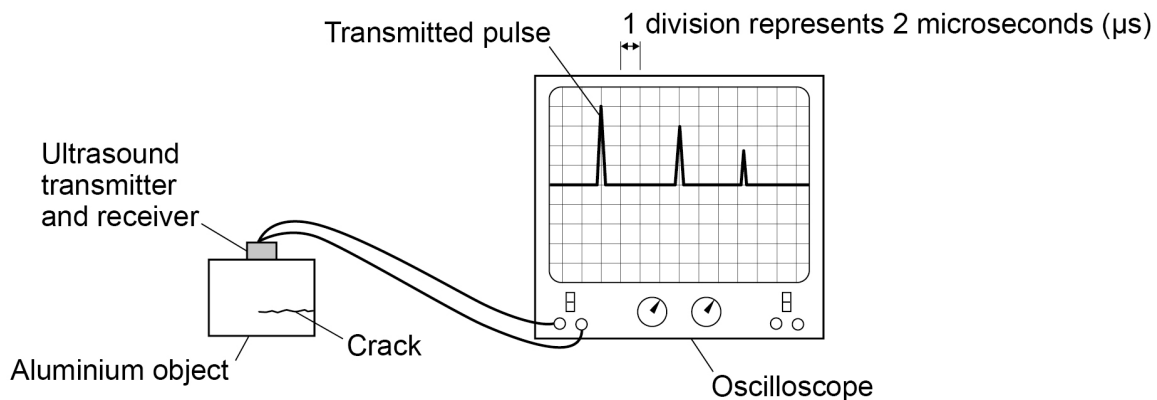

0 9 . 2 Which of the following is the same as 2 microseconds?

[1 mark]

Tick (✓) **one** box.

$2 \times 10^3 \text{ s}$

$2 \times 10^{-3} \text{ s}$

$2 \times 10^{-6} \text{ s}$

$2 \times 10^{-9} \text{ s}$

0 9 . 3 Ultrasound travels at 6300 m/s in aluminium.

Determine the depth of the crack below the top surface of the aluminium.

Use information from **Figure 17**.

Give your answer to **two** significant figures.

[4 marks]

Depth = _____ m

Question 9 continues on the next page

Turn over ►



Figure 18 shows the parts of a moving-coil microphone.

Figure 18

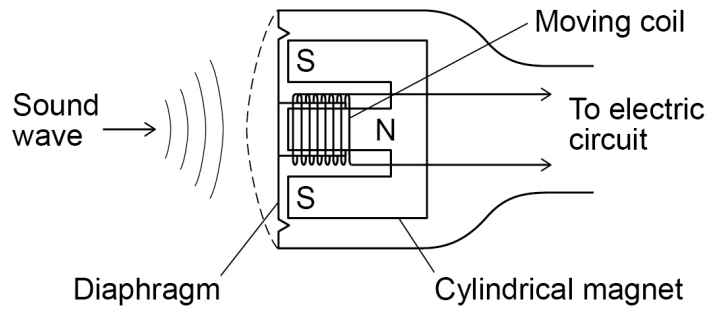

0 9 . 4 What is the function of a microphone?

[1 mark]

0 9 . 5 Explain how a moving-coil microphone works.

[4 marks]



1 0

Figure 19 shows the back of a lorry. The lorry is used to carry horses.

Figure 19

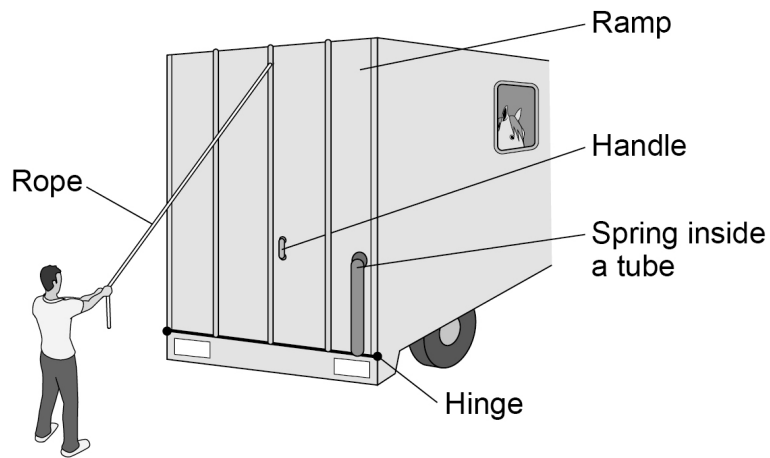

The ramp is lowered by pulling on the rope or by pulling on the handle.

The hinge acts as a pivot.

1 0 . 1

Explain why it is easier to lower the ramp by pulling on the rope rather than pulling on the handle.

[2 marks]

Question 10 continues on the next page

Turn over ►



When the ramp is lowered, work is done to stretch a spring on the side of the ramp. Elastic potential energy is stored in the stretched spring.

Figure 20 shows the ramp part way down in a balanced horizontal position.

Figure 20

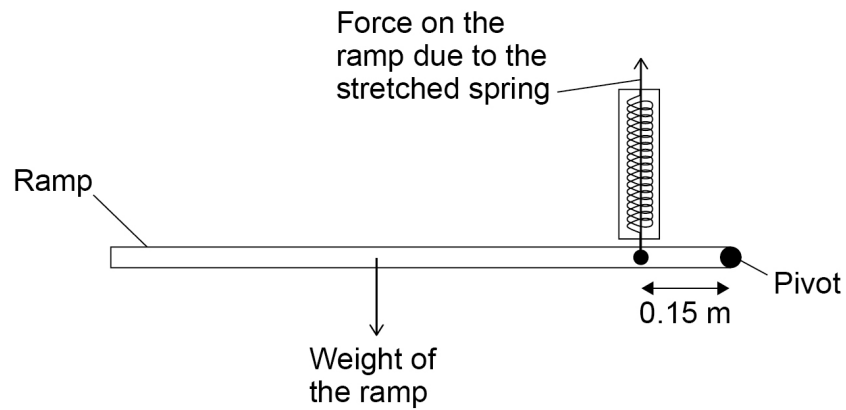

1 0 . 2 With the ramp horizontal:

the moment caused by the weight of the ramp = 924 Nm

the spring is stretched by 0.250 m

Calculate the elastic potential energy stored in the stretched spring.

Use data from **Figure 20**.

[6 marks]

Elastic potential energy = _____ J

8

END OF QUESTIONS



There are no questions printed on this page

*Do not write
outside the
box*

**DO NOT WRITE ON THIS PAGE
ANSWER IN THE SPACES PROVIDED**



There are no questions printed on this page

*Do not write
outside the
box*

**DO NOT WRITE ON THIS PAGE
ANSWER IN THE SPACES PROVIDED**

Copyright information

For confidentiality purposes, from the November 2015 examination series, acknowledgements of third-party copyright material will be published in a separate booklet rather than including them on the examination paper or support materials. This booklet is published after each examination series and is available for free download from www.aqa.org.uk after the live examination series.

Permission to reproduce all copyright material has been applied for. In some cases, efforts to contact copyright-holders may have been unsuccessful and AQA will be happy to rectify any omissions of acknowledgements. If you have any queries please contact the Copyright Team, AQA, Stag Hill House, Guildford, GU2 7XJ.

Copyright © 2019 AQA and its licensors. All rights reserved.

